

GEARTOOTH SPEED SENSOR

GS1012 Series



Flange mount gear sensor rated to 125°C.

Features

- Senses motion of ferrous geartooth targets
- Near zero speed sensing capability
- Immune to rotational alignment
- 10 bit dynamic threshold detection offers:
 - Automatically adjusting magnetic range
 - Self compensating to target geometry
 - Immune to target run out
- Compatible with unregulated power supply
- Reverse battery protected to -24VDC
- Internal circuit protection to IEC529 1000
 - EMI resistant to 10V/m, 30MHz to 1GHz
 - ESD resistant to 4kV (contact discharge)
 - Fast transient resistant to 2kV
- Conducted immunity resistant to 10VRMS@150kHz to 80MHz
- EMC compatible 30A/m@50Hz
- Meets IEC529 IP67 for dust and water protection
- Integral Connector: 3-pin Delphi Metri Pack 150.2 Series No. 12162833 mates with Delphi 12162280 and 12162279
- Discrete wire version: 22 AWG, tin plated, polyolefin insulation
- 150°C version also available. Consult factory

Applications

- Wheel speed
- Transmission speed
- Anti-lock braking systems

Specifications

Part Number	Operating Voltage Range (VDC)	Supply Current (mA max.)	Output	Output Saturation Voltage (mV max.)	Output Current (mA max.)	Operating Temp Range (°C)	Storage Temp Range (°C)	Leads	Connector
GS101201	5.0 – 24	6	sink	400	25	-40 to 125	-40 to 125	—	Delphi*
GS101202	5.0 – 24	6	sink	400	25	-40 to 125	-40 to 125	22 AWG x 1m BBB	—

*Metripak 150 Series. Mates with Delphi 12162280 and 12162279.

Notes: These sensors require the use of an external pull-up resistor, the value of which is dependent on the supply voltage. See page 18 for recommendations. Pull-up resistor should be connected between output (Black) and Vcc (Brown).

Dimensions inches (mm)

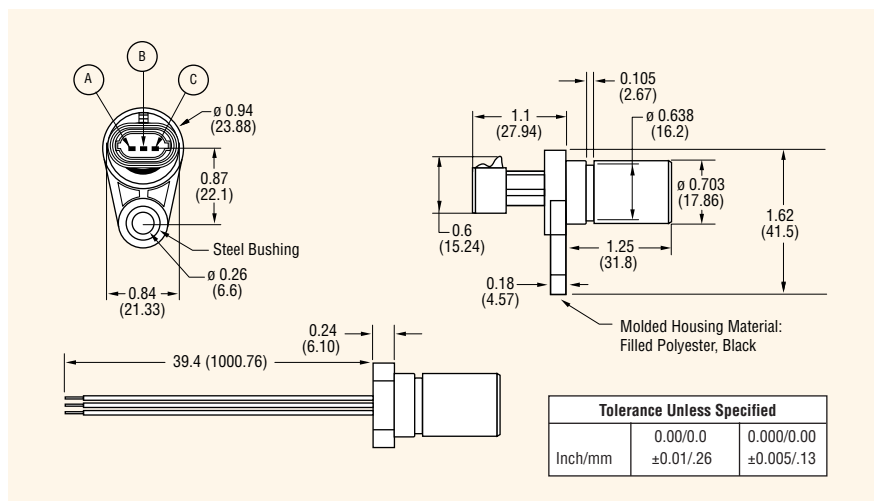

Open Collector Sinking Block Diagram

